



## Case Study: Santee Cooper

### **Rainey Generating Station (RGS) Automates Processes to Gain Step Change in Efficiency**

**William R. Finn, PE, CFII**

**Performance Services, Santee Cooper**

Santee Cooper's Rainey Generating Station (RGS) is located near Anderson, South Carolina. RGS is Santee Cooper's first natural gas fuelled combustion turbine generating plant.

#### **NEED TO MAKE OUR DATA EASILY OBTAINABLE...**

Our main goal at the new Rainey plant was to maximize the efficiency of our operations. We also needed a method to send environmental data to the Continuous Emissions Monitoring System and reduce manual data collection processes. This was inefficient in the past because we had many isolated data sources that could only be accessed manually.

A significant part of that challenge was collecting and accessing the data required for U.S. Environmental Protection Agency (EPA) reporting. We use Continuous Emissions Monitoring Systems (CEMS) to collect data for the Environmental Group at Santee Cooper. The CEMS system provides information on gas turbine operation to ensure environmental standards are enforced. This system is critical. It must function correctly and the data stream must be continuous. Emission reporting requires a minimum 98% uptime. Failure to meet reporting standards could result in fines and other penalties.

At Santee Cooper we have generation power meters that were isolated data sources. Control room operators manually read the meters, recorded the data on paper, keyed the data into an Excel spreadsheet and transferred the resulting hourly data to a corporate intranet web site. This process is prone to operator input error.

#### **RETRIEVE DATA IN REAL-TIME...**

To answer these challenges we needed to automate these processes and make our data easily available to all levels of the company. We wanted a solution with vendor neutral architectures that enabled us to use existing legacy hardware. We were also looking for a scalable solution based on standardized technology which would allow us to upgrade both software and hardware systems. MatrikonOPC provided the solution we needed.

We now retrieve the data in real-time from our devices through a firewall between the control network and the corporate network. Data is retrieved from our gas turbines through the MatrikonOPC Server for GE MarkVI, passed through the MatrikonOPC Redundancy Broker and MatrikonOPC Data Manager to the MatrikonOPC Server for Modbus. The data is pushed into Data Logger where it is recorded and then used for reporting. The client applications are

custom developed using Microsoft Visual Basic for real-time display. We configured Microsoft Excel to accept the OPC data being generated and display it in an Excel spreadsheet interface. By adding some Visual Basic code, we were able to turn Excel into a real-time data visualization tool. Operators can access real-time environmental data in a user friendly interface. MatrikonOPC ScadaModbus feeds the data into this Excel spreadsheet for real-time data calculation. Before OPC we had no way of accessing real-time data. Now it is readily accessible in real-time. We are reading and writing to 14,000 points every 5 seconds. Real-time data was also added to an existing RTX data historian for future analysis.

The MatrikonOPC Redundancy Broker and Data Manager solution makes our system fully redundant addressing our need of continual data for emissions reporting.

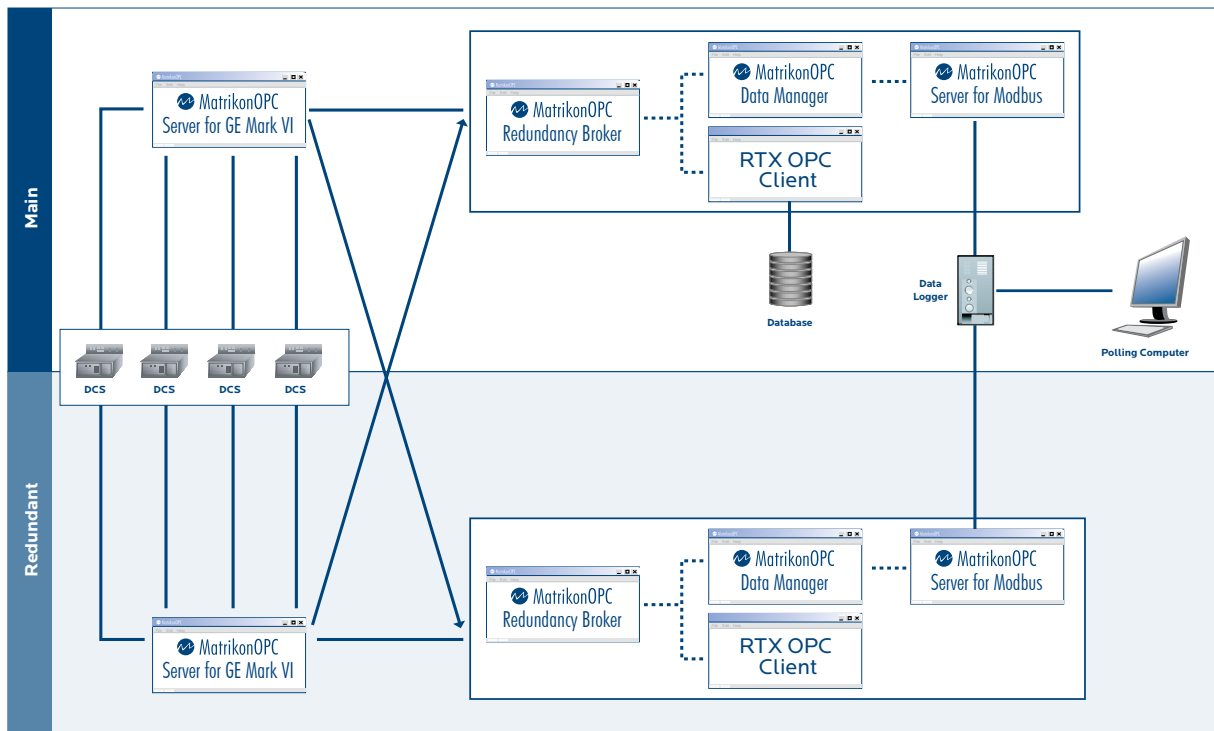

**Figure 1:** Data is retrieved in real time from RGS’s gas turbines through the MatrikonOPC Server for GE MarkVI, passed through the MatrikonOPC Redundancy Broker and MatrikonOPC Data Manager to the MatrikonOPC Server for Modbus. Then data is pushed into Data Logger where it is recorded and then used for reporting.

## EASE OF CONNECTION IMPROVES PLANT EFFICIENCY

OPC technology provides ease of access to the wide variety of devices in our enterprise, eliminating costly custom or proprietary interfaces. Providing us with a flexible and scalable solution we can build on for years to come. We are confident and secure in our ability to meet the 98% uptime emissions reporting requirements. Now that these manual processes are automated, we are saving approximately 4 hours of resource allocation in a 24 hour shift rotation.

## LOOKING AHEAD...

Rainey was the first Santee Cooper plant to implement the OPC solution. The success in automating what were once manual tasks at RGS will be employed across all of our Santee Cooper plants. We will be connecting a weather station that is currently an isolated data source using OPC. We will be able to see “real time” data and use the historical data to better forecast dike maintenance. The Performance Services staff at Santee Cooper is extremely excited about benefits of OPC, its ease of installation and simplicity of use.

## ABOUT THE AUTHOR: WILLIAM FINN, SANTEE COOPER

William has been with Santee Cooper (South Carolina Public Service Authority) for over 10 years in various roles that include Principal Engineer and Senior MIS Analyst. He is currently the Team Leader in the Performance Services Engineering Group that provides plant performance monitoring, testing, evaluation, project recommendations and

changes, and process improvement for 6 power generation stations. William's current primary projects include data collection for monitoring plant performance (especially turbine monitoring and control) for real time display, historical storage and regulatory compliance.

William graduated from Cleveland State University, Cleveland, Ohio with a Bachelors of Science in Mechanical Engineering and is a Professional Engineer in the South Carolina. William has worked for the US Navy as a Federal Employee engineer, concentrating on data communications.

#### ABOUT SANTEE COOPER

Santee Cooper serves over 138,000 retail customers in Berkeley, Georgetown, and Horry counties and supplies power to the municipalities of Bamberg and Georgetown, 32 large industries, and one military installation in North Charleston. The state-owned electric and water utility generates the power distributed by the state's 20 electric cooperatives. Santee Cooper power now flows in all 46 counties in the state serving over 625,000 customers. In addition to its original hydroelectric station, the utility owns and operates four large-scale, coal-fired generating stations in South Carolina: Jefferies Station in Moncks Corner, Cross Station in Cross, Winyah Station in Georgetown, and Grainger Station in Conway.

#### ABOUT MATRIKONOPC

MatrikonOPC is the world's largest OPC developer. MatrikonOPC is a charter member of the OPC Foundation. With a collection of more than 500 OPC products and interfaces and over 100,000 installations worldwide, MatrikonOPC is the world's largest developer, trainer and distributor of OPC products. For free downloads or more information visit [www.matrikonopc.com](http://www.matrikonopc.com).



Copyright © 2006 Matrikon, Inc.